

Model NART-R (Non-separable Type)

Optional specifications		Symbol
Material	Carbon steel	No Symbol
	Stainless steel	M
Roller guide	With cage	No Symbol
	Full rollers	V
Seal	Without seal	No Symbol
	With seal	UU
Outer ring shape	Spherical outer ring	R

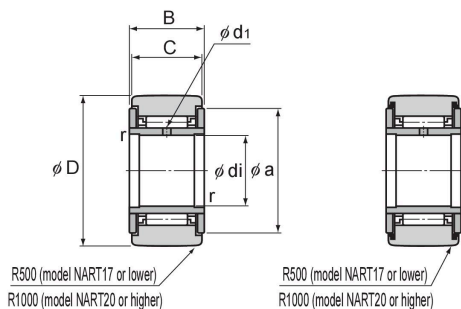

Model NART-R

Model NART-UUR

Unit: mm

Model No.	Main dimensions							Basic load rating				Track load capacity Spherical outer ring kN	Rotational speed limit*		Mass	
	Inner diameter	Outer diameter	B	C	a	r_{min}	Oil hole d_1	With cage		Full rollers			With cage	Full rollers	With cage	Full rollers
	d_i	D						C	C_0 kN	C_0 kN	C	C_0 kN	min ⁻¹	min ⁻¹	g	g
NART 5R	5	16	12	11	12	0.3	1.5	2.84	2.65	6.46	7.81	1.08	25000	10500	14.5	15.1
NART 6R	6	19	12	11	14	0.3	1.5	3.33	3.35	7.58	10.2	1.37	20000	8700	20.5	21.5
NART 8R	8	24	15	14	17.5	0.3	1.5	5.68	5.89	11.7	15.6	1.86	17000	7000	41.5	42.5
NART 10R	10	30	15	14	23.5	0.6	2	7.94	7.59	15.8	18.5	2.45	15000	5700	64.5	66.5
NART 12R	12	32	15	14	25.5	0.6	2	8.53	8.44	17	21	2.74	13000	5200	71	73
NART 15R	15	35	19	18	29	0.6	2	13.7	16.4	25.3	36.9	3.14	10000	4300	102	106
NART 17R	17	40	21	20	32.5	1	2	17.4	19.3	32	46.6	3.72	9500	3900	149	155
NART 20R	20	47	25	24	38	1	2.5	22.9	30.6	41.7	67.7	7.15	8000	3400	250	255
NART 25R	25	52	25	24	43	1	2.5	24.6	33.3	45.4	79.5	8.23	7000	3000	285	295
NART 30R	30	62	29	28	50.5	1	3	33.4	51.4	60	111	10.5	5500	2400	470	485
NART 35R	35	72	29	28	53.5	1	3	35.5	57.3	63.2	123	12.9	5000	2200	640	655
NART 40R	40	80	32	30	61.5	1	3	44.6	81.4	76.4	166	14.9	4000	1900	845	865
○ NART 45R	45	85	32	30	66.5	1	3	46.6	88.6	80.5	183	16.1	4000	1700	915	935
NART 50R	50	90	32	30	76	1	3	48.3	95.7	84.4	200	17.3	3500	1600	980	1010

Note1) ○: Model NART45R is available only in carbon steel.

Note2) The rotation speed limit value in the table (*) applies to models that have no seal and use grease lubrication. With those models using oil lubrication, up to 130% of this value is permitted. With those attached with seals, up to 70% of this value is permitted.

For information on accuracy standards, please refer to **A20-9**.

Model number coding

NART 25 M UU V R

No symbol: Carbon steel
M : Stainless steel

R : Spherical outer ring

No symbol: With cage

V : Full-roller Type

No symbol: Without seal

UU : With seal