

Models ST / ST-B

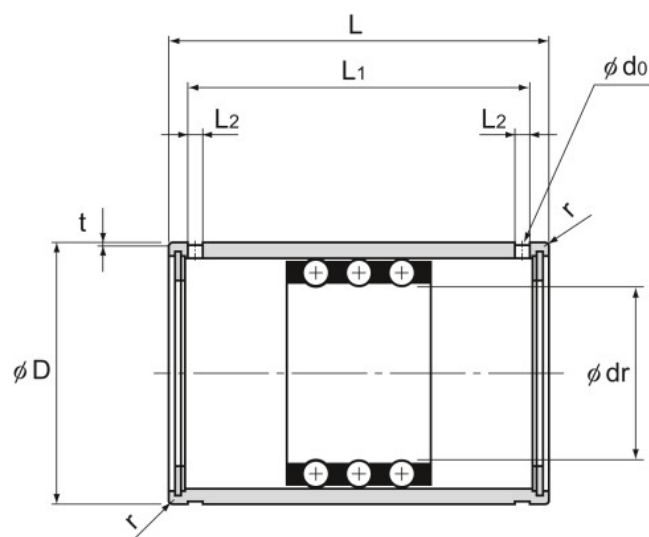

Model ST
(For light load)

Model No.	Maximum stroke	Inscribed bore diameter				Outer diameter	
		dr	Tolerance	D	Tolerance		
		ST 6	14	6	+0.018 +0.010	12	0 -0.008
ST 8 ST 8B	24 8	8	+0.022 +0.013	15			
ST 10 ST 10B	30 8	10		+0.027 +0.016	19	0 -0.009	
ST 12 ST 12B	32 8	12	23				
ST 16 ST 16B	40 16	16	28				
ST 20 ST 20B	54 28	20	+0.033 +0.020	32	0 -0.011		
ST 25 ST 25B	54 28	25		37			
ST 30 ST 30B	82 44	30		45			
ST 35 ST 35B	92 54	35	+0.041 +0.025	52	0 -0.013		