

Models ST...UU/ST...UUB

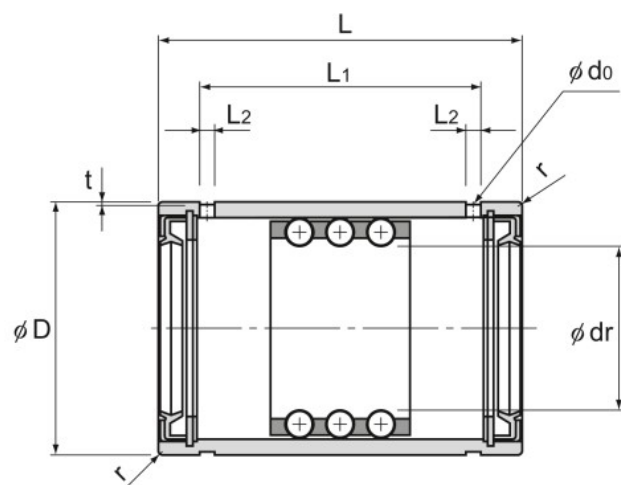

Model ST...UU
(For light load)

Model No.	Maximum stroke	Inscribed bore diameter				Outer diameter	
		dr	Tolerance	D	Tolerance		
		ST 8UU	14	8	+0.022 +0.013	15	0 -0.008
ST 10UU	16	10	+0.027 +0.016	19	0 -0.009		
ST 12UU	17	12		23			
ST 16UU	24	16		28			
ST 20UU ST 20UUB	32 12	20	+0.033 +0.020	32	0 -0.011		
ST 25UU ST 25UUB	32 12	25		37			
ST 30UU ST 30UUB	65 27	30		45			
ST 35UU ST 35UUB	75 37	35	+0.041 +0.025	52	0 -0.013		
ST 40UU ST 40UUB	91 49	40		60			
ST 45UU ST 45UUB	91 49	45		65			