

■ Z-axis Bracket A47-1N

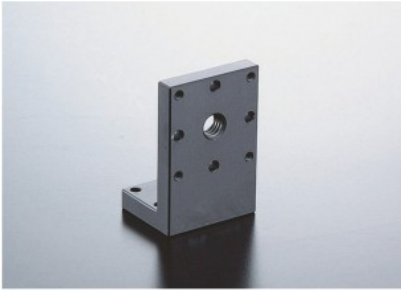

Z-axis bracket for □25mm stage.

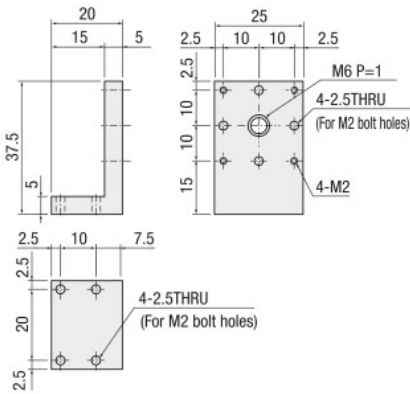

■ Z-axis Bracket A47-2



Z-axis bracket for □40mm linear stage. Attachable each bracket surface.

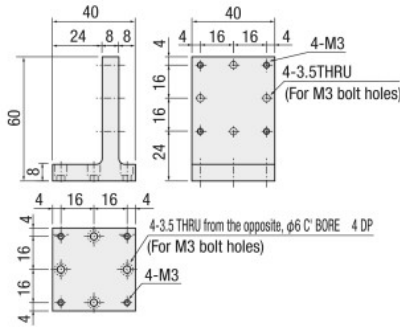

■ Z-axis Bracket A47-4

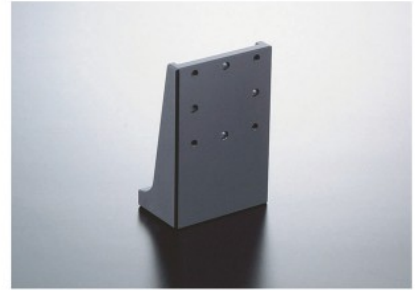

Z-axis bracket for □40mm linear stage.

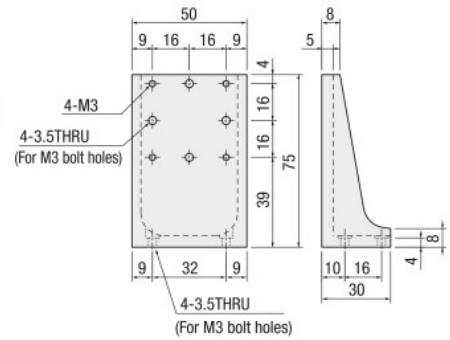

■ Z-axis Bracket A47-106



Z-axis bracket for □40mm stage.

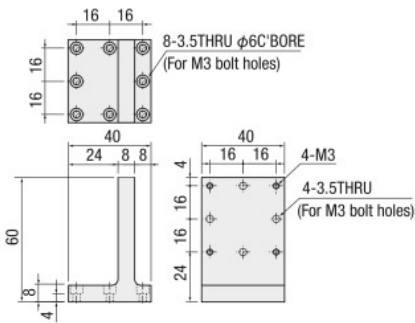

■ Stainless Z-axis Bracket AS47-2



Z-axis bracket for □40mm linear stage. Attachable each bracket surface.

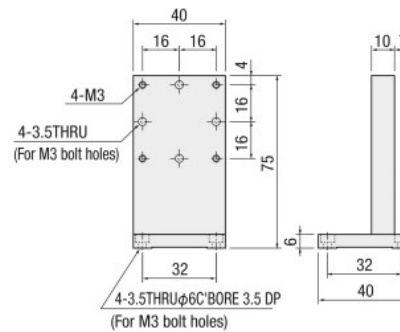

■ Z-axis Bracket A47-3



Z-axis bracket for □60mm linear stage. Attachable each bracket surface.

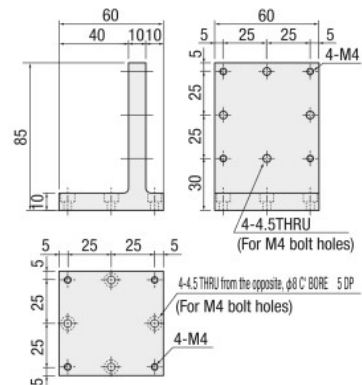

SPEC

Model	A47-1N	A47-2	A47-4	A47-106	AS47-2	A47-3
Main material—Surface finishing	Aluminum—Black alumite processing	Aluminum—Black alumite processing	Aluminum—Black alumite processing	Aluminum—Black alumite processing	Stainless	Aluminum—Black alumite processing
Weight	0.02kg	0.07kg	0.08kg	0.07kg	0.3kg	0.2kg
Provided screws (Hex socket screws)	4 of M2—8	4 of M3—8	4 of M3—8	4 of M3—8	4 of M3—6	4 of M4—10