

SOCKET HEAD CAP SCREW

(F01 SERIES)

GLOBAL STANDARD COMPONENTS

TM **NAAMS**



Assembly

07/25/08

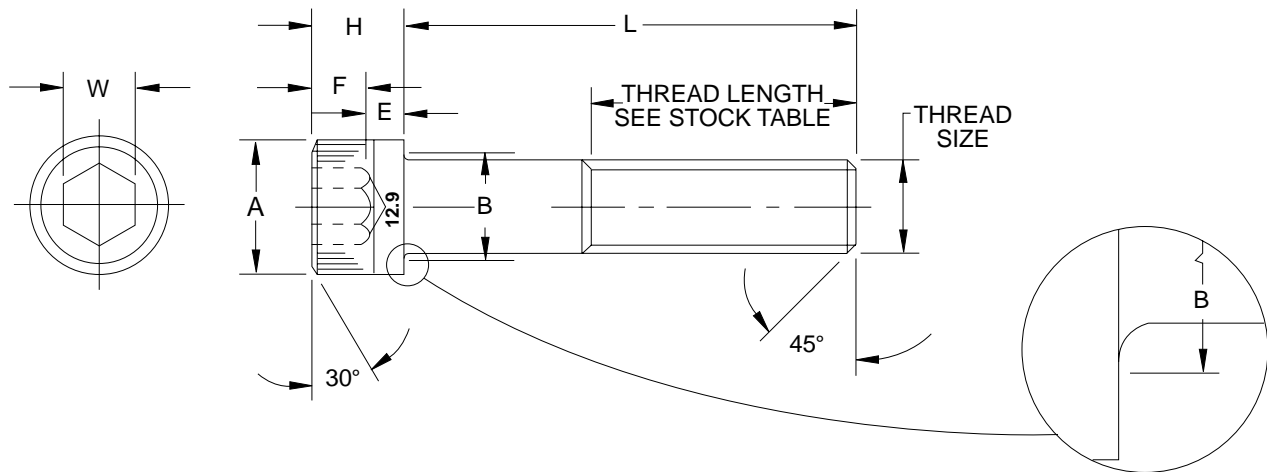

DIMENSIONS

| THREAD SIZE NOM. | PITCH | A | B | H | W | E | F |
|------------------------|-------|------|------|------|------|------|------|
| | | MAX. | MAX. | MAX. | NOM. | MIN. | MIN. |
| M3 | 0.5 | 5.5 | 3.6 | 3.0 | 2.5 | 1.02 | 1.5 |
| M4 | 0.7 | 7.0 | 4.7 | 4.0 | 3.0 | 1.52 | 2.0 |
| M5 | 0.8 | 8.5 | 5.7 | 5.0 | 4.0 | 1.90 | 2.5 |
| M6 | 1.0 | 10.0 | 6.8 | 6.0 | 5.0 | 2.28 | 3.0 |
| M8 | 1.25 | 13.0 | 9.2 | 8.0 | 6.0 | 3.2 | 4.0 |
| M10 | 1.5 | 16.0 | 11.2 | 10.0 | 8.0 | 4.0 | 5.0 |
| M12 | 1.75 | 18.0 | 14.2 | 12.0 | 10.0 | 4.8 | 6.0 |
| M16 | 2.0 | 24.0 | 18.2 | 16.0 | 14.0 | 6.4 | 8.0 |
| M20 | 2.5 | 30.0 | 22.4 | 20.0 | 17.0 | 8.0 | 10.0 |
| M24 | 3.0 | 36.0 | 26.4 | 24.0 | 19.0 | 9.6 | 12.0 |

* For hole dimensions see p F-2.1

NOTES & SPECIFICATIONS:

Material, class 12.9
ANSI B18.3.1M
ASTM A574M

CODING ON FOLLOWING PAGE

D

B

C

A

E