

New stepped millimeter graduations prevents misreading.  
Colored numbers for better design and easier-to-read.

<b>Reference standard for calibration</b> Block Gauge P42 ~49	<b>Measuring instruments</b> Indicator P242 · P248 ~249
<b>Reference plane of measurement</b> Granite Surface Plate P284	

**USE**

- For measuring of toolings and fixtures or for scribing work

**MATERIAL**

- Main & vernier scale: Stainless steel
- Base: Cast iron
- Scribe: Carbide tipped

**FEATURES**

- Stepped length of linear graduations by 1mm for easy-to-read
- Sequential graduations numbers and dot marking every 2mm for prevention of misreading.
- Decimal point on vernier makes the number easy-to-read
- Colored numbers for better design and easier-to-read
- Main scale slider enables easier adjustment
- Easy reading with magnifier lens (×3.0)
- Fine adjustment carriage to feed the slider finely
- With carbide tipped scriber
- Please use dial indicator holder when use
- Made of stainless steel for easy anti-rust treatment



VHK-30KDS

● DIMENSIONS & NAME OF PARTS (VHK-20KDS)

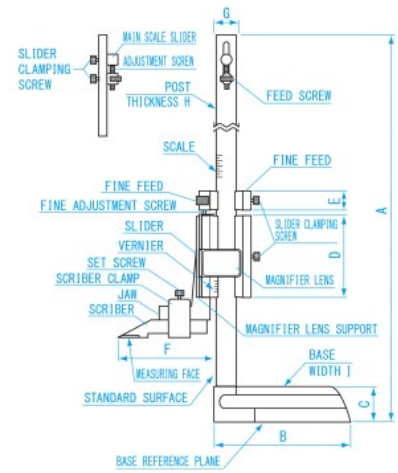

Units: mm

Model No.	A	B	C	D	E	F	G	H	I
VHK-20KDS	391	103	28	67	20	77	22	6	60
VHK-30KDS	540	125	40	75					

**ACCESSORIES**

- Dial indicator holder
- Scriber
- Magnifier lens for main scale

Order No.	Model No.	Measuring Range (mm)	Resolution (mm)	Accuracy (mm)	Slider Fine Feed (mm)	Weight
151269	VHK-20KDS	200	0.05	± 0.05	8	1.7kg
151270	VHK-30KDS	300	0.02	± 0.04		3.1kg

CALIPER  
SCRIBING CALIPER  
DEPTH GAUGE  
HEIGHT GAUGE

**CARBIDE TIPPED SCRIBER**



**Rust prevention**  
Zerust Film for Steel  
 P380

● DIMENSIONS Units: mm

**FEATURES**

- Scriber for height gauges

**MATERIAL**

- Stainless steel
- Carbide tipped

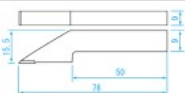

Order No.	Model No.	Applicable Height Gauge	Weight
151043	SVH-1520	VHK-20KDS VHK-30KDS VHK-15 VHK-20 VHK-30 VHK-60	45g

**SCRIBER CLAMP**



**Rust prevention**  
Zerust Film for Steel  
 P380

● DIMENSIONS Units: mm

**FEATURES**

- Scriber clamp for height gauges

**MATERIAL**

- Stainless steel



Order No.	Model No.	Applicable Height Gauge	Weight
151268	VHK-C	VHK-20KDS VHK-30KDS VHK-15 VHK-20 VHK-30 VHK-60	50g

**INDICATOR HOLDER**



**Rust prevention**  
Zerust Film for Steel  
 P380

**FEATURES**

- Indicator holder for height gauges

**MATERIAL**

- Steel

**SPECIFICATIONS**

- φ6mm, φ8mm, dovetail mount
- Arm length: Approx. 60mm

Order No.	Model No.	Applicable Height Gauge	Weight
151275	TVH-1520	VHK-20KDS VHK-30KDS VHK-15 VHK-20 VHK-30 VHK-60	75g