

# 20K Gate Valve

**20SLB**  
B.B.I.S.  
RF-flanged

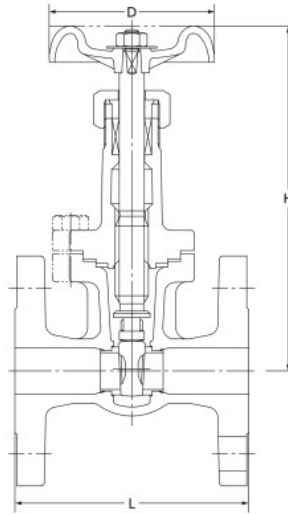

Face to face : JIS B 2002 JV 4-4  
End connection : JIS B 2239 20K

120°C Static water..... 2.8MPa  
220°C Steam, air, gas, oil..... 2.5MPa  
300°C Steam, air, gas, oil..... 2.3MPa  
350°C Steam, air, gas, oil..... 2.0MPa  
● Use for lubricating or hydraulic oil is acceptable.

**Materials**

Parts	JIS material
Body	FCD-S
Bonnet	FCD-S
Stem	SUS420J2
Disc	SCS1
Body seat ring	403SS
Gland	SUS420J2 (40 : 403SS)
Gland packing	Non-asbestos Packing
Handwheel	Ductile Iron
Wheel nut	Carbon Steel
Bonnet bolt	Carbon Steel
Gasket	Non-asbestos Sheet
Name plate	Aluminum

**Dimensions**

Size	mm					
	mm	15	20	25	32	40
	inch	1/2	3/4	1	1 1/4	1 1/2
L		108	117	127	140	165
H (open)		176	177	214	242	277
D		90	90	100	115	135

NOTE : For flange dimensions, refer to Page 44.

# 20K Gate Valve

**20SLBO**  
B.B.O.S.Y.  
RF-flanged

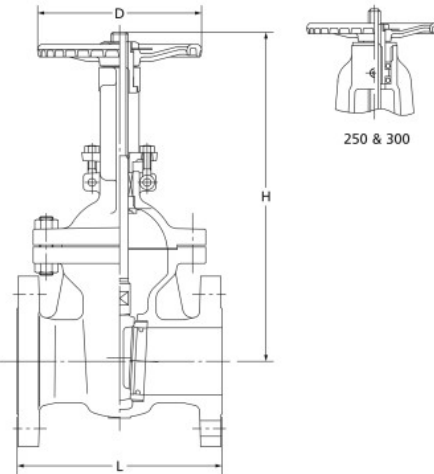

Face to face : JIS B 2002  
End connection : JIS B 2239 20K

120°C Static water..... 2.8MPa  
220°C Steam, air, gas, oil..... 2.5MPa  
300°C Steam, air, gas, oil..... 2.3MPa  
350°C Steam, air, gas, oil..... 2.0MPa  
● Use for lubricating or hydraulic oil is acceptable.

**Materials**

Parts	JIS material
Body	FCD-S
Bonnet	FCD-S
Stem	403SS
Disc	SCS1 (40) 403SS (50~150) SCPH2+13cr (200~300)
Body seat ring	403SS
Gland	FCD-S
Gland packing	Non-asbestos Packing
Handwheel	Ductile Iron
Wheel nut	Carbon Steel
Bonnet bolt/nut	Carbon Steel
Gland bolt/nut	Carbon Steel
Yoke sleeve	High Tension Brass (150~200 : Cast Brass)
Gasket	Non-asbestos Sheet
Name plate	Aluminum

**Dimensions**

Size	mm										
	mm	40	50	65	80	100	125	150	200	250	300
	inch	1 1/2	2	2 1/2	3	4	5	6	8	10	12
L		190	216	241	283	305	381	403	419	457	502
H (open)		326	402	456	518	599	725	847	1076	1239	1448
D		160	200	200	250	250	300	350	400	450	500

NOTE : For flange dimensions, refer to Page 44.