

3 STAINLESS STEEL BUTT-WELDING FITTINGS

45° LONG RADIUS ELBOWS

45E(L) OR 45LR

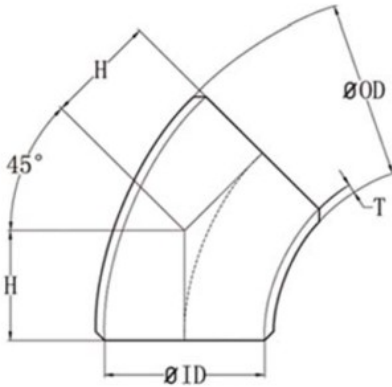
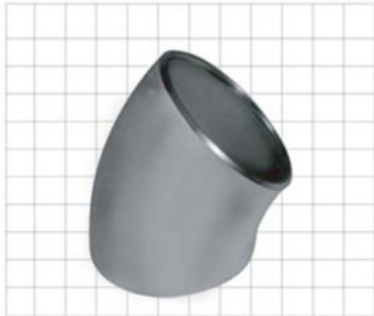

GB													Unit:mm
NPS		Outside diam		SCH 5S			SCH 10S			SCH 40S			Center to end H
A	B	OD I	OD II	Thickness T	ID I	ID II	Thickness T	ID I	ID II	Thickness T	ID I	ID II	
15A	1/2"	21.3	18.00	1.65	18.03	14.70	2.11	16.43	17.08	2.77	15.80	12.46	16
20A	3/4"	26.9	25.00	1.65	23.37	21.70	2.11	22.45	22.68	2.87	20.93	19.28	19
25A	1"	33.7	32.00	1.65	30.10	28.70	2.77	27.86	28.16	3.38	26.64	25.24	22
32A	1.1/4"	42.4	38.00	1.65	38.86	34.70	2.77	36.63	36.86	3.56	35.05	30.88	25
40A	1.1/2"	48.3	45.00	1.65	44.96	41.70	2.77	42.72	42.76	3.68	40.89	37.64	29
50A	2"	60.3	57.00	1.65	57.02	53.70	2.77	54.79	54.76	3.91	52.50	49.18	35
65A	2.1/2"	73.0	76.00	2.11	68.81	71.78	3.05	66.93	66.90	5.16	62.71	65.68	44
80A	3"	88.9	89.00	2.11	84.68	84.78	3.05	82.80	82.80	5.49	77.93	78.02	51
90A	3.1/2"	101.6	----	2.11	97.38	----	3.05	95.50	95.50	5.74	90.12	----	57
100A	4"	114.3	108.00	2.11	112.19	103.78	3.05	108.20	108.20	6.02	102.26	95.96	64
125A	5"	141.3	133.00	2.77	135.76	127.46	3.40	134.49	134.50	6.55	128.19	119.90	79
150A	6"	168.3	159.00	2.77	162.74	153.46	3.40	161.47	161.50	7.11	154.05	144.78	95
200A	8"	219.1	219.00	2.77	213.54	213.46	3.76	211.56	211.58	8.18	202.72	202.64	127
250A	10"	273.0	273.00	3.40	266.24	266.20	4.19	264.67	264.62	9.27	254.51	254.46	159
300A	12"	323.9	325.00	3.96	315.93	317.08	4.57	314.71	314.76	9.53	304.80	305.94	190
350A	14"	355.6	377.00	3.96	347.68	369.09	4.78	346.05	346.04	----	----	----	222
400A	16"	406.4	426.00	4.19	398.02	417.62	4.78	396.85	396.84	----	----	----	254
450A	18"	457.0	480.00	4.19	448.82	471.62	4.78	447.65	447.44	----	----	----	286
500A	20"	508.0	530.00	4.78	498.45	520.44	5.54	496.93	496.92	----	----	----	318
550A	22"	559.0	----	4.78	549.25	----	5.54	547.73	547.92	----	----	----	343
600A	24"	610.0	630.00	5.54	598.53	618.92	6.35	596.90	597.30	----	----	----	381
650A	26"	660.0	----	----	----	----	----	----	----	----	----	----	406
700A	28"	711.0	720.00	----	----	----	----	----	----	----	----	----	438
750A	30"	762.0	----	6.35	749.30	----	7.92	746.15	746.16	----	----	----	470
800A	32"	813.0	820.00	----	----	----	----	----	----	----	----	----	502

ASME									Unit:mm
NPS		Outside diam OD	SCH 5S		SCH 10S		SCH 40S		Center to end H
A	B		Thickness T	ID	Thickness T	ID	Thickness T	ID	
15A	1/2"	21.3	1.65	18.03	2.11	16.43	2.77	15.80	16
20A	3/4"	26.7	1.65	23.37	2.11	22.45	2.87	20.93	19
25A	1"	33.4	1.65	30.10	2.77	27.86	3.38	26.64	22
32A	1.1/4"	42.2	1.65	38.86	2.77	36.63	3.56	35.05	25
40A	1.1/2"	48.3	1.65	44.96	2.77	42.72	3.68	40.89	29
50A	2"	60.3	1.65	57.02	2.77	54.79	3.91	52.50	35
65A	2.1/2"	73.0	2.11	68.81	3.05	66.93	5.16	62.71	44
80A	3"	88.9	2.11	84.68	3.05	82.80	5.49	77.93	51
90A	3.1/2"	101.6	2.11	97.38	3.05	95.50	5.74	90.12	57
100A	4"	114.3	2.11	112.19	3.05	108.20	6.02	102.26	64
125A	5"	141.3	2.77	135.76	3.40	134.49	6.55	128.19	79
150A	6"	168.3	2.77	162.74	3.40	161.47	7.11	154.05	95
200A	8"	219.1	2.77	213.54	3.76	211.56	8.18	202.72	127
250A	10"	273.0	3.40	266.24	4.19	264.67	9.27	254.51	159
300A	12"	323.8	3.96	315.93	4.57	314.71	9.52	304.80	190
350A	14"	355.6	3.96	347.68	4.78	346.05	----	----	222
400A	16"	406.4	4.19	398.02	4.78	396.85	----	----	254
450A	18"	457.0	4.19	448.82	4.78	447.65	----	----	286
500A	20"	508.0	4.78	498.45	5.54	496.93	----	----	318
550A	22"	559.0	4.78	549.25	5.54	547.73	----	----	343
600A	24"	610.0	5.54	598.53	6.35	596.90	----	----	381
650A	26"	660.0	----	----	----	----	----	----	406
700A	28"	711.0	----	----	----	----	----	----	438
750A	30"	762.0	6.35	749.30	7.92	746.15	----	----	470
800A	32"	813.0	----	----	----	----	----	----	502

JIS										Unit:mm
NPS		Outside diam OD	SCH 5S		SCH 10S		SCH 40S		Center to end H	
A	B		Thickness T	ID	Thickness T	ID	Thickness T	ID		
15A	1/2"	21.7	1.65	18.4	2.1	17.5	2.8	16.1	15.8	
20A	3/4"	27.2	1.65	23.9	2.1	23.0	2.9	21.4	15.8	
25A	1"	34.0	1.65	30.7	2.8	28.4	3.4	27.2	15.8	
32A	1.1/4"	42.7	1.65	39.4	2.8	37.1	3.6	35.5	19.7	
40A	1.1/2"	48.6	1.65	45.3	2.8	43.0	3.7	41.2	23.7	
50A	2"	60.5	1.65	57.2	2.8	54.9	3.9	52.7	31.6	
65A	2.1/2"	76.3	2.1	72.1	3.0	70.3	5.2	65.9	39.5	
80A	3"	89.1	2.1	84.9	3.0	83.1	5.5	78.1	47.3	
90A	3.1/2"	101.6	2.1	97.4	3.0	95.6	5.7	90.2	55.3	
100A	4"	114.3	2.1	110.1	3.0	108.3	6.0	102.3	63.1	
125A	5"	139.8	2.8	134.2	3.4	133.0	6.6	126.6	78.9	
150A	6"	165.2	2.8	159.6	3.4	158.4	7.1	151	94.7	
200A	8"	216.3	2.8	210.7	4.0	208.3	8.2	199.9	126.3	
250A	10"	267.4	3.4	260.6	4.0	259.4	9.3	248.8	157.8	
300A	12"	318.5	4.0	310.5	4.5	309.5	10.3	297.9	189.4	
350A	14"	355.6	4.0	347.6	5.0	345.6	11.1	333.4	220.9	
400A	16"	406.4	4.5	397.4	5.0	396.4	12.7	381	252.5	
450A	18"	457.2	4.5	448.2	5.0	447.2	14.3	428.6	284.1	
500A	20"	508.0	5.0	498.0	5.5	497.0	15.1	477.8	315.6	
550A	22"	558.8	5.0	548.8	5.5	547.8	15.9	527	347.2	
600A	24"	609.6	5.5	598.6	6.5	596.6	17.5	574.6	378.7	
650A	26"	660.4	5.5	649.4	8.0	644.4	18.9	622.6	410.3	
700A	28"	711.2	5.5	700.2	8.0	695.2	----	----	441.9	
750A	30"	762.0	6.5	749.0	8.0	746.0	----	----	473.4	
800A	32"	812.8	----	----	8.0	796.8	----	----	505	