

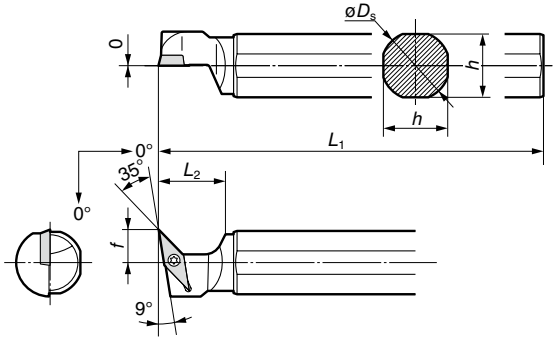

## General Turning

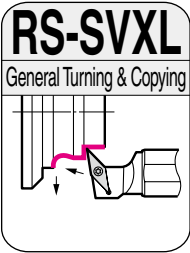

### Parts

|             |                  |
|-------------|------------------|
|             |                  |
|             | (For Torx Holes) |
| Screw       | Wrench           |
| BFTX02507NT | RT08             |

### Holder

Above figures show left hand tools.

| Cat. No.      | Stock | Dimensions (mm) |     |       |      |       |          | Applicable Insert |
|---------------|-------|-----------------|-----|-------|------|-------|----------|-------------------|
|               |       | $\phi D_s$      | $h$ | $L_1$ | $f$  | $L_2$ |          |                   |
| RS15H-SVXL11  | ●     | 15.875          | 15  | 100   | 10.0 | 20    | VC□□1103 |                   |
| RS19X-SVXL11  | ●     | 19.05           | 18  | 120   | 10.0 | 20    |          |                   |
| RS20X-SVXL11S | ●     | 20              | 19  | 95    | 10.0 | 20    |          |                   |
| RS20X-SVXL11  | ●     | 20              | 19  | 120   | 10.0 | 20    |          |                   |
| RS22X-SVXL11  | ●     | 22              | 21  | 120   | 10.0 | 20    |          |                   |
| RS25X-SVXL11  | ●     | 25.4            | 24  | 150   | 10.0 | 20    |          |                   |

\* Right handed or neutral handed inserts are applicable. [Insert selection](#) From D32

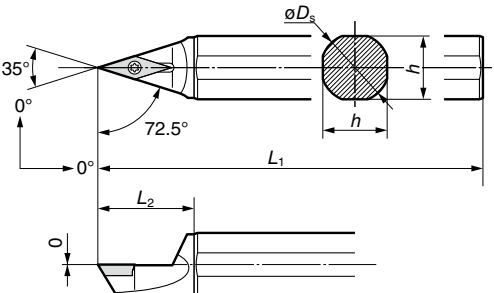
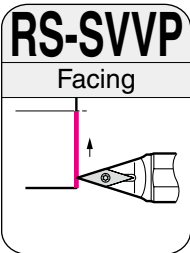

### Parts

|             |                  |
|-------------|------------------|
|             |                  |
|             | (For Torx Holes) |
| Screw       | Wrench           |
| BFTX02507NT | RT08             |

### Holder

| Cat. No.      | Stock | Dimensions (mm) |     |       |      |       |          | Applicable Insert |
|---------------|-------|-----------------|-----|-------|------|-------|----------|-------------------|
|               |       | $\phi D_s$      | $h$ | $L_1$ | $f$  | $L_2$ |          |                   |
| RS19X-SVVPN11 | ●     | 19.05           | 18  | 120   | 9.0  | 27    | VP□□1103 |                   |
| RS22X-SVVPN11 | ●     | 22              | 21  | 120   | 10.5 | 27    |          |                   |

[Insert selection](#) D33

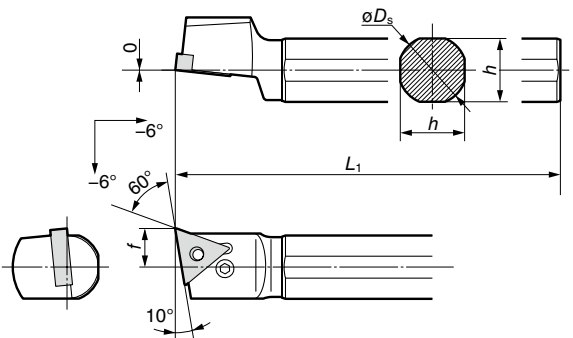
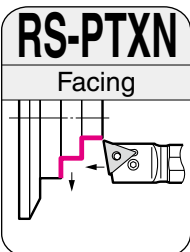

### Parts

|           |         |                       |
|-----------|---------|-----------------------|
|           |         |                       |
|           |         | (For Hexagonal Holes) |
| Lever Pin | Screw   | Wrench                |
| LCL33NT   | LCS33NT | LH020NT               |

### Holder

Above figures show left hand tools.

| Cat. No.      | Stock | Dimensions (mm) |     |       |      |  |          | Applicable Insert |
|---------------|-------|-----------------|-----|-------|------|--|----------|-------------------|
|               |       | $\phi D_s$      | $h$ | $L_1$ | $f$  |  |          |                   |
| RS19X-PTXNL16 | ●     | 19.05           | 18  | 120   | 11.0 |  | TN□□1604 |                   |
| RS20X-PTXNL16 | ●     | 20              | 19  | 120   | 11.0 |  |          |                   |
| RS25M-PTXNL16 | ●     | 25.4            | 24  | 150   | 13.0 |  |          |                   |

\* Right handed or neutral handed inserts are applicable. [Insert selection](#) From B54