

Bowed Washers

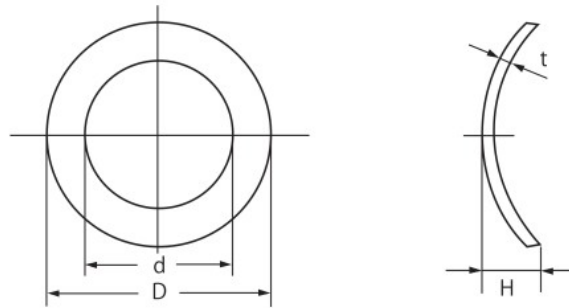

Unit: mm

Size-No.	d		D		H		t
	Basic	Tol.	Basic	Tol.	Basic	Tol.	
MB-	4301	4.3	6.8	-	1	±0.2	0.15
	4302	4.3	8	±0.2	1.2		0.3
	5011	5	7.9	+0.05 -0.15	1.2	±0.15	0.15
	5301	5.3	10	±0.2	1.4	±0.2	0.3
	6203	6.2	11		1.4		0.15
	6301	6.3	11		1.5		0.4

Material = Carbon spring steel. Hardness = HRC40 ~50. Finish = Phosphate coating (ACP).

Note

1. Our products with little marketability may not be in stock. When employing our products, consult with us for their availability.

Dish Washers

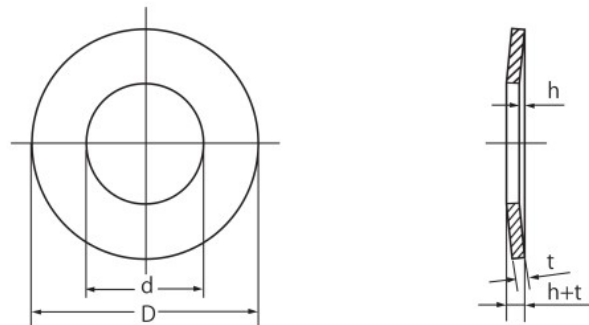

Unit: mm

Size-No.	d		D		H (Heavy duty)				L (Light duty)			
	Basic	Tol.	Basic	Tol.	t		h (Approx.)	h + t (Approx.)	t		h (Approx.)	h + t (Approx.)
					Basic	Tol.			Basic	Tol.		
DB-	4	4.2	8	±0.3	0.4	±0.03	0.2	0.6	0.3	±0.025	0.25	0.55
	5	5.2	10		0.5		0.25	0.75	0.4		0.3	0.7
	6	6.2	12.5		0.7	±0.04	0.3	1	0.5	±0.03	0.35	0.85
	7	7.2	14		0.8		0.3	1.1	0.5		0.4	0.9
	8	8.2	16		0.9	±0.05	0.35	1.25	0.6	±0.04	0.45	1.05
	9	9.2	18	1	0.4		1.4	0.7	0.5		1.2	
	10	10.2	20	1	0.45		1.45	0.8	0.55		1.35	
	11	11.2	22.5	1.2	±0.06	0.5	1.7	0.8	±0.05	0.65	1.45	
	12	12.2	25	1.5		0.55	2.05	0.9		0.7	1.6	
	14	14.2	28	1.5		0.65	2.15	1		0.8	1.8	
	16	16.3	31.5	1.75	±0.5	0.7	2.45	1.2	±0.06	0.9	2.1	
	18	18.3	35.5	2		0.8	2.8	1.2		1	2.2	
	20	20.4	40	2		0.9	2.9	1.5		1.15	2.65	
	22	22.4	45	2.5		±0.08	1	3.5		1.75	1.3	3.05
	25	25.4	50	3		±0.07	1.1	4.1		2	1.4	3.4
	28	28.5	56	3	1.3		4.3	2	1.6	3.6		
	30	31	63	3.5	±0.09		1.4	4.9	2.5	1.75	4.25	
	35	36	71	4	±0.08	1.6	5.6	2.5	2	4.5		
	40	41	80	5		1.7	6.7	3	2.3	5.3		
	45	46	91	5		±0.09	2	7	3.5	2.5	6	
50	51	100	6	±0.15	2.2	8.2	3.5	2.8	6.3			

Material = Carbon spring steel. Hardness = HRC40 ~50. Finish = Phosphate coating (ACP).

Note

1. Our products with little marketability may not be in stock. When employing our products, consult with us for their availability.