

WG-1

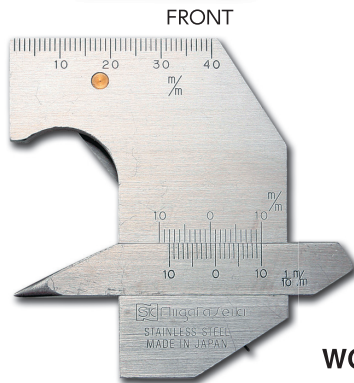

WG-2

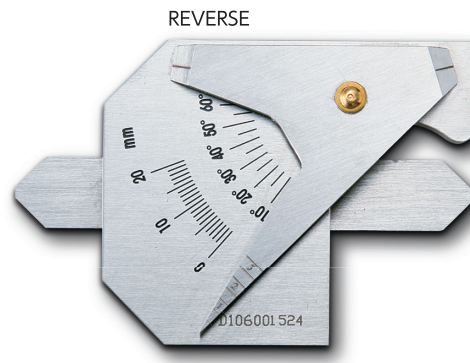
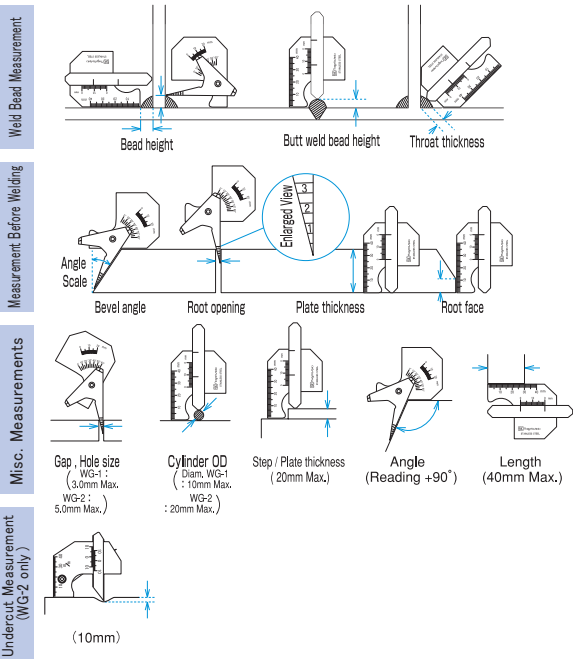

DIMENSIONS

Units : mm

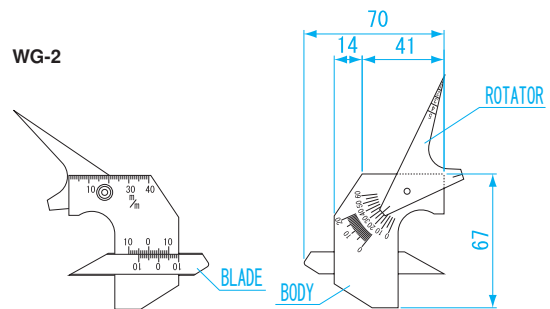
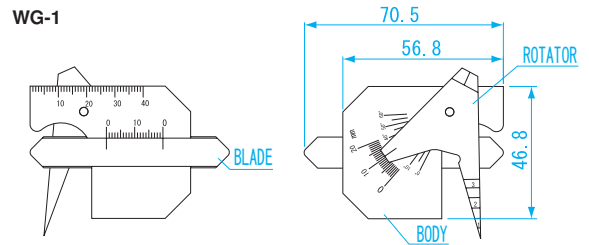

BLOCK GAUGES

PIN GAUGES

PIN VISE

PIN GAUGE ACCESSORIES

GAUGES

THREAD GAUGES

PLUG GAUGES

RING GAUGES

THICKNESS GAUGES

TAPER GAUGES

WELDING GAUGES

OTHER GAUGES

- USE** • For measuring fillet weld, bead weld, etc.
- MATERIAL** • Stainless steel (SUS410)
- FEATURES** • Efficient for welding and quality control
• Tough and portable (with vinyl case)

Order No.	Model No.	Measurement Accuracy for Throat Thickness of Fillet Weld	Bevel Angle Accuracy	Accuracy	Weight
007502	WG-1 (M)	± 0.4mm	± 0.7°	± 0.4mm	79g
007503	WG-2 (L)	± 0.2mm	± 0.7°	± 0.4mm	91g