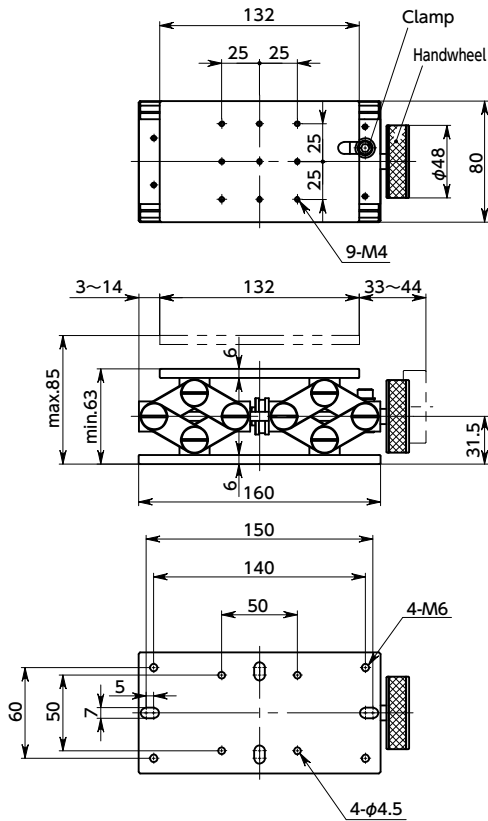
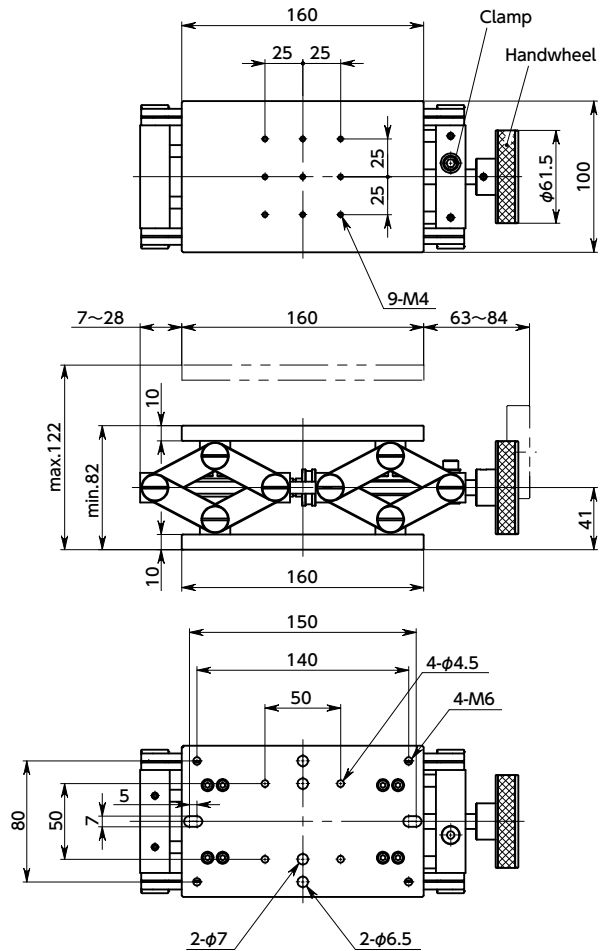

TLJK Jackscrew

[WEB Selection Tool](#)
[WEB CAD Download](#)
TLJK-1

TLJK-2

- For vertical micromotion of heavy object.
- Turn the handwheel to make smooth and parallel up / down movement.
- The stage position can be fixed by clamping the handwheel axis.
- Made of Aluminum.Light weight.

Material/Finish

	TLJK
Stage	Aluminum Alloy Alumite Treatment (Black)
Lower surface spacer	Aluminum Alloy Alumite Treatment (Black)

Unit : mm

Part Number	Stage Face	Travel Guide	Travel distance	Parallelism	Position Resolution	Withstand load (N)	Mass (g)
TLJK-1	80×132	Pantograph Mechanism	22	0.1	0.1	196	2300
TLJK-2	100×160	Pantograph Mechanism	40	0.1	0.1	245	3400
TLJK-3	160×220	Pantograph Mechanism	70	0.1	0.1	294	5900

- Hexagon wrench for mounting and hex socket head cap screws (M6 x 12 **TLJK-1** and M6 x 16 **TLJK-2 TLJK-3**) are provided.