

BVREF-2

CBN V形R付エンドミル
CBN 2 Flutes R type Endmill

- 高硬度材・焼入れ鋼の直彫り加工。
Direct cutting for Highly hardened material and Quenching steel
- V溝、文字彫加工に最適。
Most suitable for V groove and engraving processing

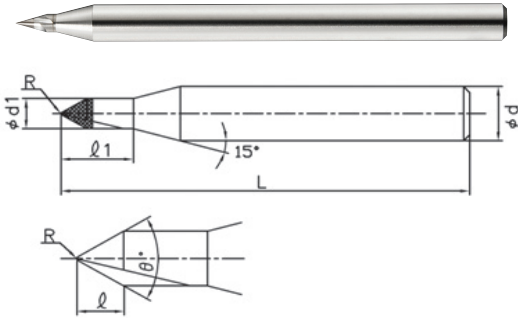

CBN CBN立方晶窒化ホウ素 Cubic Boron Nitride

柄径の許容差 Shank Diameter Tolerance
d 0~-0.003

ネジレ角0° Twist Angle 0°
(直刃2枚刃) (2 Flutes Straight Endmill)

先端角度 Edge Angle
+15~-15

R許容差 R Tolerance
±0.02

●切削条件表はP49に記載

●Cutting conditions are recommended on page 49.

[寸法単位 : mm]

[size : mm]

品番 Code No.	先端角 θ Edge Angle	先端R Edge R	有効長 l_1 Effective Length	刃長 l Flute Length	首径 d_1 Neck Diameter	CBN層 CBN Length	全長 L Total Length	柄径 d Shank Diameter	備考 Remarks
BVREF-2030010	30°	R 0.1	6	3.64	2	2	50	4	
BVREF-2030020	30°	R 0.2	6	3.54	2	2	50	4	
BVREF-2040010	40°	R 0.1	4	2.68	2	2	50	4	
BVREF-2040020	40°	R 0.2	4	2.61	2	2	50	4	
BVREF-2060010	60°	R 0.1	4	1.69	2	2	50	4	
BVREF-2060020	60°	R 0.2	4	1.65	2	2	50	4	
BVREF-2090010	90°	R 0.1	4	0.975	2	2	50	4	
BVREF-2090020	90°	R 0.2	4	0.95	2	2	50	4	