

H-2B • H-2LB

0-25 mm
Measurement Range

0-45 mm
Measurement Range

These stands support measurement of outer diameters within the range of 0 to 25 mm.

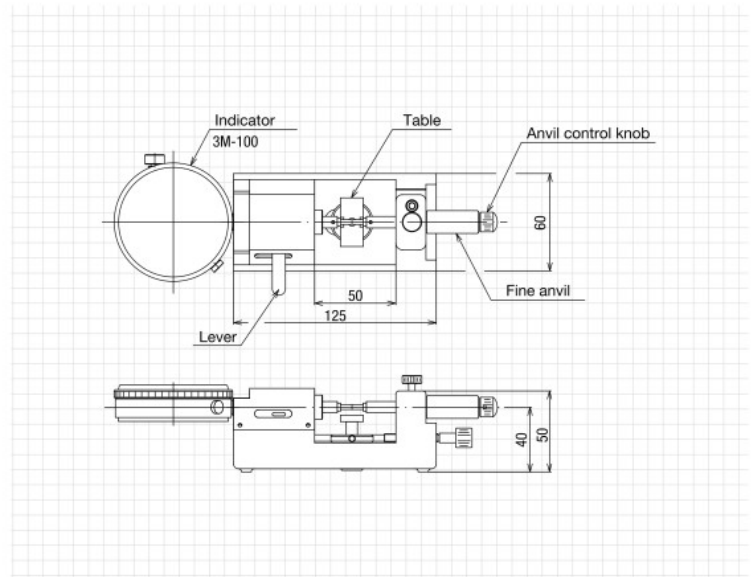

Model	H-2B		H-2LB	
	Without indicator	With indicator 3M-100	Without indicator	With indicator 3M-100
Measurement range	0 to 25 mm		18 to 45 mm	
Precision	—		—	
Measuring force	As per the indicator's measuring force		As per the indicator's measuring force	
Standard contact point *1	F-150		F-150	

*1 Various other contact points are available.

BST-1B

4-67 mm
Measurement Range

This stand supports measurement of inner diameters within the range of 4 to 67 mm.

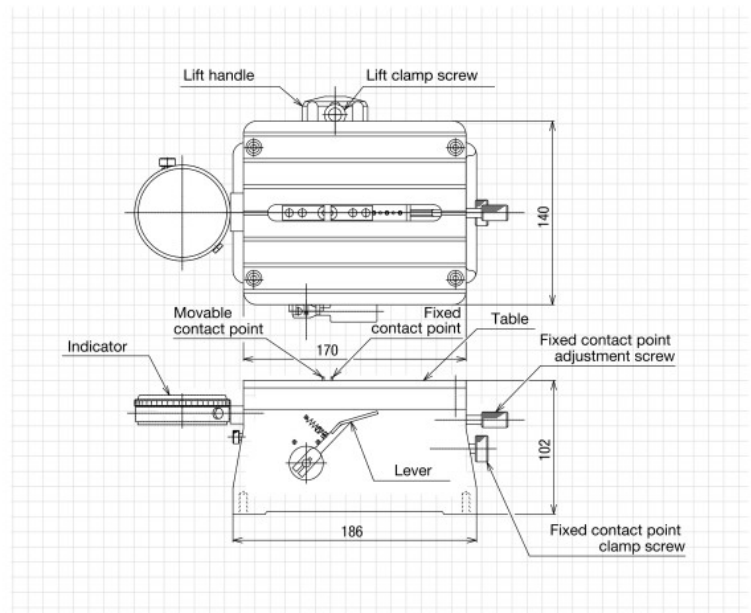

Model	BST-1B	
	Without indicator	With indicator 3M-100
Measurement range	φ4 to 67 mm	
Measurement depth adjustment	15 mm	
Measuring force	0.98 to 2.94 N	
Contact point stroke	3 mm	
Standard contact point	F-050	

◇ Because this inner diameter measuring instrument is a comparative measuring instrument, a reference gauge is required. Error will result if the dimensional difference between this gauge and the target workpiece is large.