

タッチコネクター

TOUCH CONNECTOR

エルボコネクター [金属] ELBOW CONNECTOR [METAL BODY]

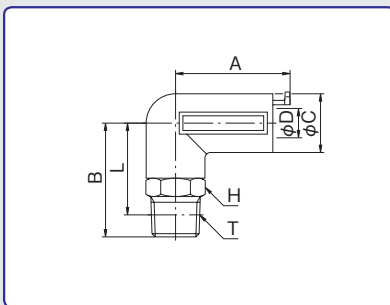

型式 Model	A	B	ϕC	適用 チューブ 外径 Tube O. D. ϕD	二面幅 Spanner Flats H1	L	ねじ サイズ Thread T	有効断面積 Effective Section Area (mm^2)		チューブ 挿入寸法 Tube Insertion Depth	重量 Weight (g)
								ウレタン Polyurethane Tube	ナイロン Nylon Tube		
CKL-4-M5	26.2	21.5	12.0	4	10.0	18.0	M5×0.8	2.9	3.0	19.5	28.2
CKL-4-01	26.2	25.5	12.0	4	10.0	21.5	R1/8	3.1	5.4	19.5	31.8
CKL-4-02	26.2	28.5	12.0	4	14.0	22.5	R1/4	3.1	5.4	19.5	36.2
CKL-6-01	29.7	27.0	14.0	6	12.0	23.0	R1/8	9.0	10.0	22.5	44.6
CKL-6-02	29.7	30.0	14.0	6	14.0	24.0	R1/4	9.1	10.5	22.5	45.0
CKL-6-03	29.7	31.0	14.0	6	17.0	24.6	R3/8	9.1	10.5	22.5	55.4
CKL-8-01	31.2	28.0	16.0	8	14.0	24.0	R1/8	15.5	22.0	22.5	60.8
CKL-8-02	31.2	31.0	16.0	8	14.0	25.0	R1/4	15.5	22.0	22.5	61.4
CKL-8-03	31.2	32.0	16.0	8	17.0	25.6	R3/8	15.5	22.0	22.5	68.8
CKL-10-01	34.9	28.0	18.0	10	17.0	24.0	R1/8	18.5	22.0	25.0	62.4
CKL-10-02	34.9	31.0	18.0	10	17.0	25.0	R1/4	26.0	33.0	25.0	67.8
CKL-10-03	34.9	32.0	18.0	10	17.0	25.6	R3/8	26.0	33.0	25.0	71.6
CKL-10-04	34.9	36.0	18.0	10	21.0	28.0	R1/2	26.0	33.0	25.0	83.6
CKL-12-02	38.4	35.0	21.0	12	19.0	29.0	R1/4	36.0	41.0	27.2	95.2
CKL-12-03	38.4	36.0	21.0	12	19.0	29.6	R3/8	40.0	48.0	27.2	99.8
CKL-12-04	38.4	39.0	21.0	12	21.0	31.0	R1/2	40.0	48.0	27.2	113.2

エルボコネクター [樹脂] ELBOW CONNECTOR [RESIN BODY]

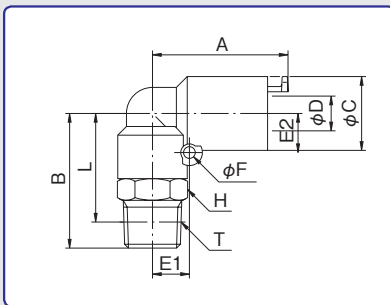

型式 Model	A	B	ϕC	適用 チューブ 外径 Tube O. D. ϕD	E1	E2	ϕF	二面幅 Spanner Flats H1	L	ねじサイズ Thread T	有効断面積 Effective Section Area (mm^2)		チューブ 挿入寸法 Tube Insertion Depth	重量 Weight (g)
											ウレタン Polyurethane Tube	ナイロン Nylon Tube		
RKL-4-M5	26.2	21.5	13.0	4	7.0	7.5	2.7	10.0	18.0	M5×0.8	2.9	3.0	19.5	12.4
RKL-4-01	26.2	25.5	13.0	4	7.0	7.5	2.7	10.0	21.5	R1/8	3.1	5.4	19.5	16.0
RKL-4-02	26.2	28.5	13.0	4	7.0	7.5	2.7	14.0	22.5	R1/4	3.1	5.4	19.5	20.6
RKL-6-01	29.7	27.0	15.0	6	7.5	8.0	2.7	12.0	23.0	R1/8	9.0	10.0	22.5	20.2
RKL-6-02	29.7	30.0	15.0	6	7.5	8.0	2.7	14.0	24.0	R1/4	9.1	10.5	22.5	22.6
RKL-6-03	29.7	31.0	15.0	6	7.5	8.0	2.7	17.0	24.6	R3/8	9.1	10.5	22.5	34.8
RKL-8-01	31.2	28.0	17.0	8	8.5	9.0	2.7	14.0	24.0	R1/8	15.5	22.0	22.5	27.4
RKL-8-02	31.2	31.0	17.0	8	8.5	9.0	2.7	14.0	25.0	R1/4	15.5	22.0	22.5	31.4
RKL-8-03	31.2	32.0	17.0	8	8.5	9.0	2.7	17.0	25.6	R3/8	15.5	22.0	22.5	34.8
RKL-10-01	34.9	28.0	19.0	10	9.0	10.3	2.7	17.0	24.0	R1/8	18.5	22.0	25.0	31.2
RKL-10-02	34.9	31.0	19.0	10	9.0	10.3	2.7	17.0	25.0	R1/4	26.0	33.0	25.0	35.0
RKL-10-03	34.9	32.0	19.0	10	9.0	10.3	2.7	17.0	25.6	R3/8	26.0	33.0	25.0	39.0
RKL-10-04	34.9	36.0	19.0	10	9.0	10.3	2.7	21.0	28.0	R1/2	26.0	33.0	25.0	54.6
RKL-12-02	38.4	35.0	22.0	12	11.0	12.2	2.7	19.0	29.0	R1/4	36.0	41.0	27.2	50.6
RKL-12-03	38.4	36.0	22.0	12	11.0	12.2	2.7	19.0	29.6	R3/8	40.0	48.0	27.2	54.6
RKL-12-04	38.4	39.0	22.0	12	11.0	12.2	2.7	21.0	31.0	R1/2	40.0	48.0	27.2	66.4

※上記に表示されていない単位は全てmm