

Internal structure and parts list

HMVC2-8-4H
HSVC2-8 to 20-4H

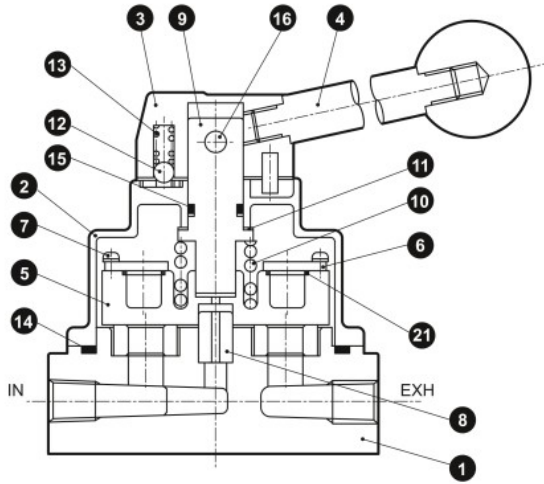

HMVO2-8-4H
HSVO2-8 to 20-4H

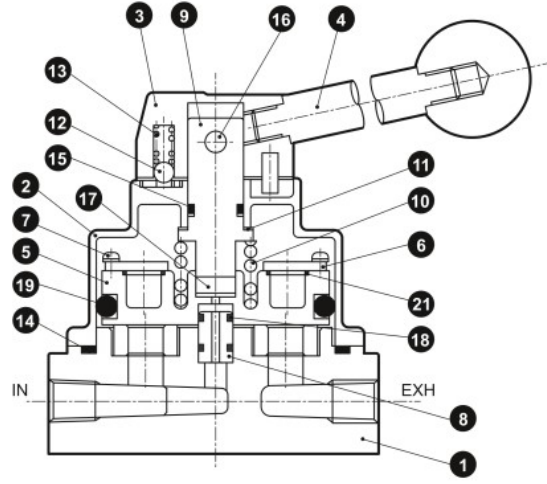

HMVC2-8-4V
HSVC2-8 to 15-4V

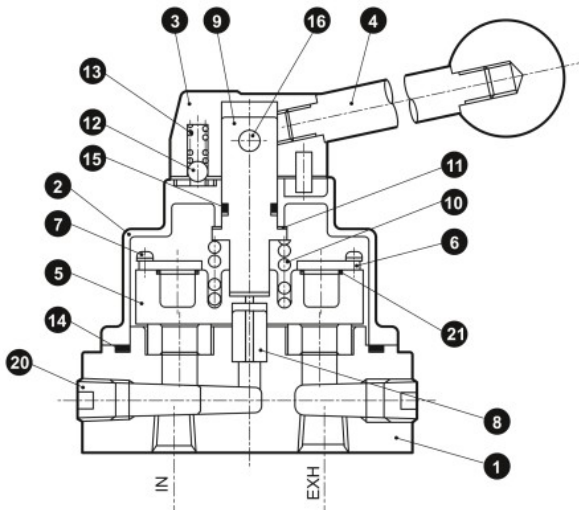

HMVO2-8-4V
HSVO2-8 to 15-4V

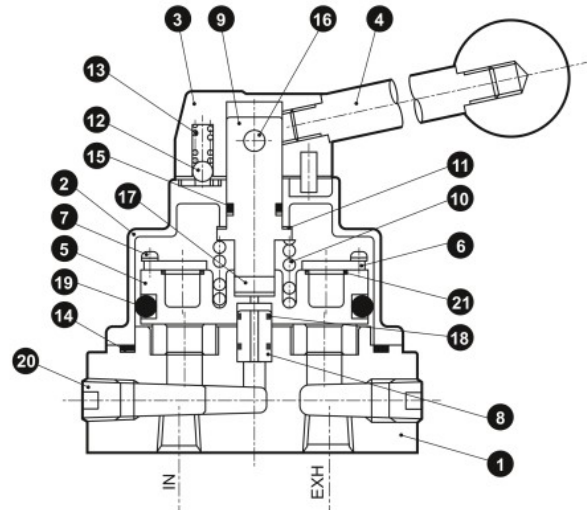

Main parts list

No.	Part name	Material	No.	Part name	Material
1	Body assembly	Zinc alloy die-casting tetrafluoroethylene resin (other than port size 20)	11	Washer	Special polyethylene
			12	Ball	Stainless steel
			13	Spring	Stainless steel
		Aluminum alloy die-casting tetrafluoroethylene resin (port size 20 only)	14	O-ring	Nitrile rubber
			15	O-ring	Nitrile rubber
			16	Pin	Steel
2	Cover assembly	Zinc alloy die-casting	17	Spindle guide	Steel (HSVO2 only)
3	Handle head	Zinc alloy die-casting	18	O-ring	Nitrile rubber
4	Handle assembly	Steel, urea resin	19	O-ring	Nitrile rubber
5	Slide ring	Zinc alloy die-casting	20	Hexagon socket head cap plug	Steel
6	Plate	Steel	21	Gasket	Nitrile rubber
7	Cross-recessed tapping screw	Steel			
8	Rod	Steel			
9	Spindle	Stainless steel			
10	Spring	Piano wire			

4GA/B
M4GA/B
MN4GA/B
4GA/B (master)
4GB With sensor
4GD/E
M4GD/E
MN4GD/E
4GA4/B4
MN3E
MN4E
W4GA/B2
W4GB4
MN3S0
MN4S0
4SA/B0
4KA/B
4KA/B (master)
4F
4F (master)
PV5G
GMF
PV5
GMF
PV5S-0
3Q
MV3QR
3MA/B0
3PA/B
P/M/B
NP/NAP
NVP
4G*0EJ
4F*0EX
4F*0E
HMV
HSV
2QV
3QV
SKH
Silencer
TotAirSys (Total Air)
TotAirSys (Gamma)
Ending